



RESTAURANT RANGES

CHALLENGER XL GAS RESTAURANT RANGE 6 OPEN BURNERS WITH FLAME FAILURE PROTECTION 36" WIDE GAS RANGE



Model C36SFF-6BN
(shown with optional adjustable casters)



- C36SFF-6BN** 1 Standard Oven / Natural Gas
- C36SFF-6BP** 1 Standard Oven / Propane
- C36CFF-6BN** 1 Convection Oven / Natural Gas
- C36CFF-6BP** 1 Convection Oven / Propane

STANDARD FEATURES

- Fully MIG welded frame
- Stainless steel front, sides, backriser, lift-off shelf
- 6" stainless steel adjustable legs
- Six open top burners, each burner is 30,000 BTU/hr. with lift-off burner heads
- Flame failure protection; all burners, range top and oven
- Manual rotary piezo pilot igniter system
- Heavy duty cast grates, easy lift-off 12" x 12½" in front and 12" x 14½" in the rear
- Extra deep pull out stainless steel crumb tray with welded corners
- 35,000 BTU/hr. baker's depth standard oven cavity. Full size sheet pans fit side-to-side or front-to-back.
- Oven thermostat adjusts from 250°F to 500°F
- Two oven racks and four rack positions
- 35,000 BTU/hr. convection oven in place of standard oven, 24"d x 26¾"w x 14½"h (115v - 1 phase blower motor 4 amp, 6' cord and plug), includes three oven racks. Full size sheet pans only fit side-to-side in convection oven. Convection oven motor requires field attachment.
- One year limited parts and labor warranty

SPECIFICATIONS

36" wide gas restaurant range, Wolf Model No. C36SFF-6BN with flame failure protection on range top and oven burners. Fully MIG welded frame for added durability. Stainless steel front, sides, backriser, lift-off shelf and 6" adjustable legs. Six 30,000 BTU/hr. open top burners, with lift-off burner heads. Flame failure protection burners use a simple, manual rotary piezo pilot igniter system for reliability. Heavy duty cast grates, easy lift-off 12" x 12½" in the front and 12" x 14½" in the rear to better accommodate stock pots or large pans. Grates have built-in aeration bowl for greater efficiency. Burner knobs are cool to the touch, high temperature material. One oven: 35,000 BTU/hr. standard bakers depth ovens with porcelain oven bottom and door panel, measures 27"d x 26½"w x 14"h. Oven thermostat adjusts from 250°F to 500°F with a low setting. Oven is supplied with two oven racks, two rack guide sets, and four rack positions. Oven door is heavy duty with an integrated door hinge/spring mechanism requiring no adjustment. ¾" rear gas connection and pressure regulator. Total input 215,000 BTU/hr.

Exterior Dimensions:

34"d x 36"w x 58"h on 6" adjustable legs

ACCESSORIES (Packaged & Sold Separately)

- Extra oven rack with rack guides
- Casters (set of four)
- Leveling casters (set of four)
- Flanged feet (set of four)
- 10" stainless steel stub back
- Reinforced high shelf for mounting salamander broiler
- Hot tops



a division of ITW Food Equipment Group LLC

CHALLENGER XL GAS RESTAURANT RANGE

6 OPEN BURNERS WITH FLAME FAILURE PROTECTION

36" WIDE GAS RANGE

INSTALLATION INSTRUCTIONS

1. A pressure regulator sized for this unit is included. Natural gas 5.0" W.C., propane gas 10.0" W.C.
2. Gas line connecting to range must be $\frac{3}{4}$ " or larger. If flexible connectors are used, the inside diameter must be $\frac{3}{4}$ " or larger.
3. An adequate ventilation system is required for commercial cooking equipment. Information may be obtained by writing to the National Fire Protection Association, 1 Batterymarch Park, Quincy, MA 02269, www.NFPA.org. When writing, refer to NFPA No. 96.
4. These units are manufactured for installation in accordance with ANSZ223.1A (latest edition), National Fuel Gas Code. Copies may be obtained from The American Gas Association, 400 N Capitol St. NW, Washington, DC 20001, www.AGA.org.

5. **Clearances**

	Rear	Sides
Combustible	6"	10"
Standard Oven Non-combustible	0"	0"
Convection Oven Non-combustible	Min. 4"	0"
6. For proper combustion, install equipment on adjustable legs or casters provided with unit.

NOTE: In line with its policy to continually improve its product, Vulcan reserves the right to change materials and specifications without notice.

**Specify type of gas when ordering.
Specify altitude when above 2,000 feet.**

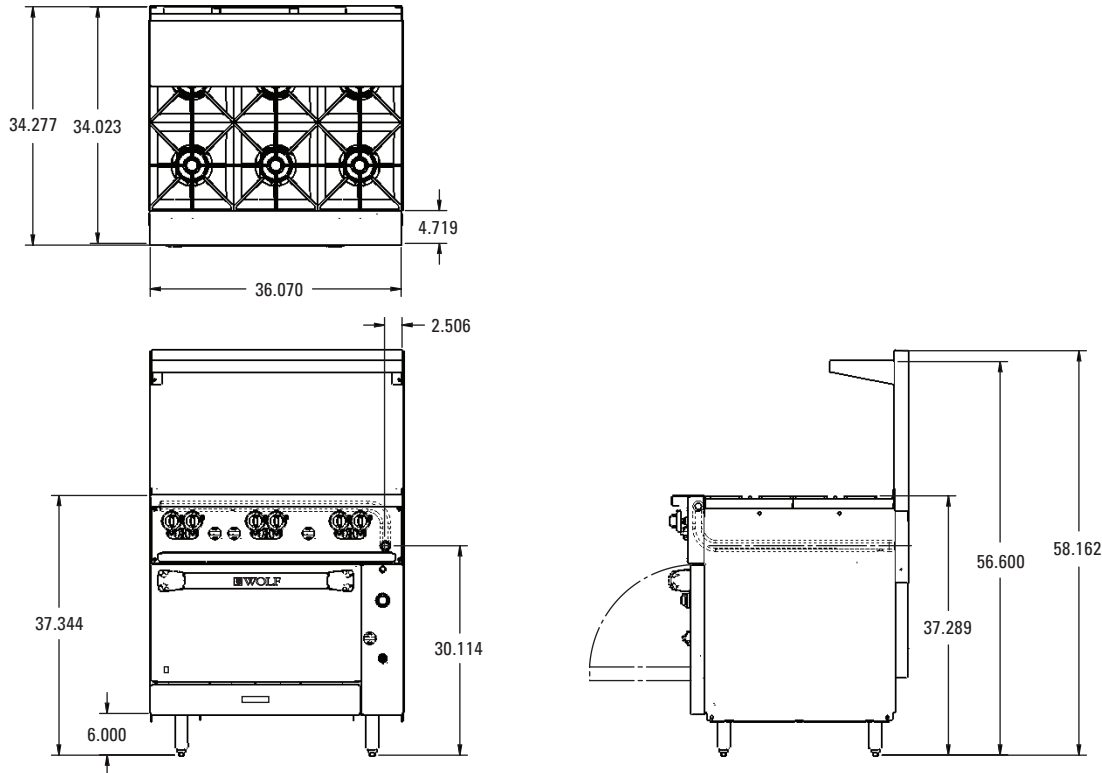

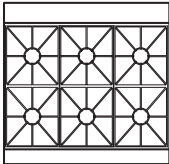
TOP CONFIGURATION	MODEL NUMBER	DESCRIPTION	TOTAL INPUT BTU / HR	SHIPPING WEIGHT LBS / KG
	C36SFF-6BN	1 Standard Oven / 6 Burners / Natural Gas	215,000	520 / 236
	C36SFF-6BP	1 Standard Oven / 6 Burners / Propane	215,000	520 / 236
	C36CFF-6BN	1 Convection Oven / 6 Burners / Natural Gas	215,000	580 / 263
	C36CFF-6BP	1 Convection Oven / 6 Burners / Propane	215,000	580 / 263

This appliance is manufactured for commercial use only and is not intended for home use.