



## RESTAURANT RANGES

# CHALLENGER XL GAS RESTAURANT RANGE

## 2 OPEN BURNERS

### 12" WIDE GAS RANGE



**Model C12-2BN**  
(shown with optional casters)



- C12-2BN** 1 Standard Oven / Natural Gas
- C12-2BP** 1 Standard Oven / Propane

### STANDARD FEATURES

- Fully MIG welded frame
- Stainless steel front, sides and backriser
- 6" stainless steel adjustable legs
- Two open top burners, each burner is 30,000 BTU/hr. with lift-off burner heads
- Shrouded flash tube pilot system (one pilot per two burners)
- Heavy duty cast grates, easy lift-off 12" x 12½" in front and 12" x 14½" in the rear
- Extra deep pull out crumb tray with welded corners
- One year limited parts and labor warranty

### ACCESSORIES (Packaged & Sold Separately)

- Casters (set of four)
- Leveling casters (set of four)
- Flanged feet (set of four)

### OPTIONS (Factory Installed)

- Flame Safety device with manual spark ignition for all open top burners, thermostatic griddles and oven pilots

### SPECIFICATIONS

12" wide gas restaurant range, Wolf Challenger XL Model No. C12-2BN. Fully MIG welded aluminized steel frame for added durability. Stainless steel front, sides, backriser and 6" adjustable legs. Extra deep crumb tray with welded corners. Two 30,000 BTU/hr. open top burners with lift-off burner heads. Energy saving flashtube open burner ignition system (one pilot for every two burners) shrouded for reliability. Heavy duty cast grates, easy lift-off 12" x 12½" in the front and 12" x 14½" in the back to better accommodate stock pots or large pans. Grates have a built in aeration bowl for greater efficiency. Burner knobs are cool to the touch, high temperature material. ¾" rear gas connection and pressure regulator. Total input 60,000 BTU/hr.

#### Exterior Dimensions:

34"d x 12"w x 58"h on 6" adjustable legs

## CHALLENGER XL GAS RESTAURANT RANGE

### 2 OPEN BURNERS 12" WIDE GAS RANGE

#### INSTALLATION INSTRUCTIONS

1. A pressure regulator sized for this unit is included. Natural gas 5.0" W.C., propane gas 10.0" W.C.
2. Gas line connecting to range must be 3/4" or larger. If flexible connectors are used, the inside diameter must be 3/4" or larger.
3. An adequate ventilation system is required for commercial cooking equipment. Information may be obtained by writing to the National Fire Protection Association, 1 Batterymarch Park, Quincy, MA 02269, www.NFPA.org. When writing, refer to NFPA No. 96.
4. These units are manufactured for installation in accordance with ANSZ223.1A (latest edition), National Fuel Gas Code. Copies may be obtained from The American Gas Association, 400 N Capitol St. NW, Washington, DC 20001, www.AGA.org.
5. **Clearances**

|                                 | Rear    | Sides |
|---------------------------------|---------|-------|
| Combustible                     | 6"      | 10"   |
| Standard Oven Non-combustible   | 0"      | 0"    |
| Convection Oven Non-combustible | Min. 4" | 0"    |
6. For proper combustion, install equipment on adjustable legs or casters provided with unit.

**NOTE:** In line with its policy to continually improve its product, Vulcan reserves the right to change materials and specifications without notice.

**Specify type of gas when ordering.  
Specify altitude when above 2,000 feet.**

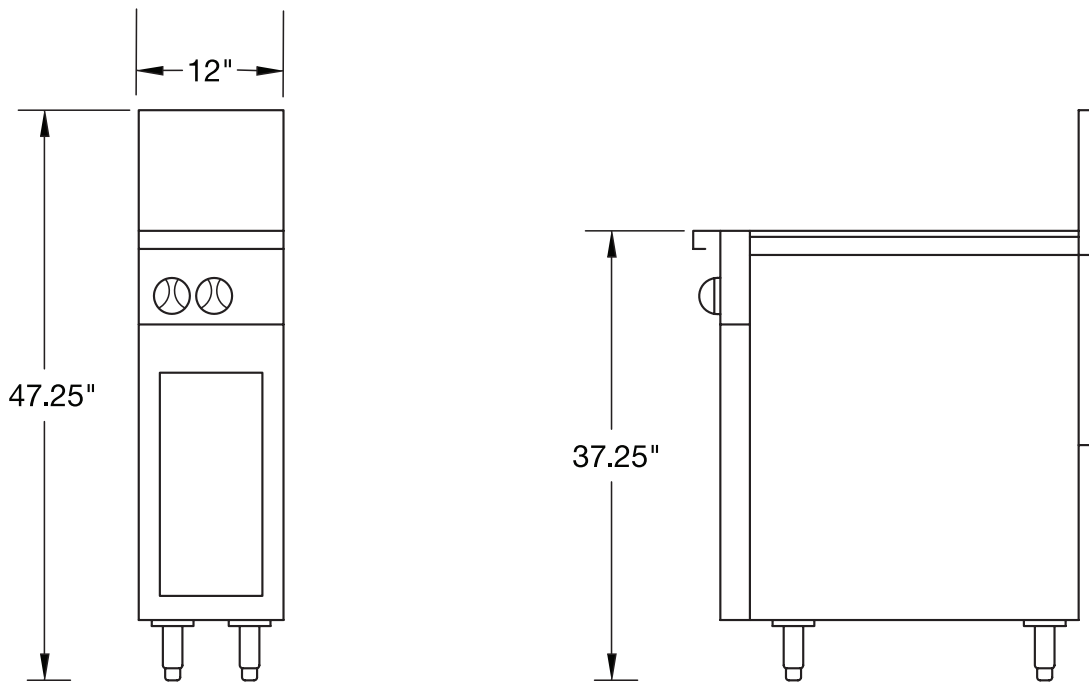

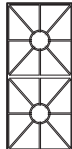
| TOP CONFIGURATION   | MODEL NUMBER | DESCRIPTION             | TOTAL INPUT BTU / HR | SHIPPING WEIGHT LBS / KG |
|---|--------------|-------------------------|----------------------|--------------------------|
|  | C12-2BN      | 2 Burners / Natural Gas | 60,000               | 350 / 159                |
|   | C12-2BP      | 2 Burners / Propane     | 60,000               | 350 / 159                |

This appliance is manufactured for commercial use only and is not intended for home use.