

HOLDING & TRANSPORT**VULCAN****VBP7I
HOLDING & TRANSPORT CABINET**

Model VBP7I

**SPECIFICATIONS**

Vulcan Hart Model No. VBP7I heated holding and transport cabinets. Blower motor for gentle and even temperature distribution. Complete with full perimeter bumper and 5" heavy duty casters (2 swivel with brakes and 2 rigid). Recessed control panel containing dual indicator light, thermometer, and full range thermostat for temperatures up to 190°F (88°C). Cabinet capacity is 7 each 18" x 26" sheet pans, 14 each 12" x 20" x 2 1/2" steam table pans, or a combination of both on 3" centers. Complete with 4 pairs of universal tray slides adjustable on 1 1/2" centers. Cabinet interior and exterior are both constructed out of 20 gauge stainless steel. Recessed side-mounted lift handles, magnetic action door latch, and full insulation; 1 1/2" in side walls and 2" in top. Welded tubular steel frame for maximum strength. Complete with top mounted cord, cord wrap, and plug: NEMA 5-15 for 120 volts and NEMA 6-15 for 208-240 volts. 120 volts, 1,200 watts, 10 amps. Lifetime warranty on heating elements.

Exterior Dimensions:

29" W x 33 3/4" D x 40" H

UL listed. UL listed to Canadian safety standards, Classified by UL to NSF Std. #4.

STANDARD FEATURES

- Holding and Transport Capacity:
 - 7 each – 18" x 26" sheet pans
 - 14 each – 12" x 20" x 2 1/2" pans or a combination of both on 3" centers
- Blower motor for gentle and even temperature distribution
- Full perimeter bumper
- 5" heavy duty casters (2 with swivel with brakes and 2 rigid)
- Recessed side mounted lift handles
- Recessed control panel
- Dual indicator lights
- Thermometer
- Full range thermostat for temperatures up to 190°F (88°C)
- Four pairs of universal tray slides adjustable on 1 1/2" centers
- Interior and the exterior are both constructed out of 20 gauge stainless steel
- Fully insulated with 1 1/2" in side walls and 2" in top
- Welded tubular steel frame for maximum strength
- Magnetic action door latch
- Top mounted cord
- Complete with cord and plug: NEMA 5-15 for 120 volts and NEMA 6-15 for 208-240 volts
- 120 volt, 1,200 watts, 10 amps
- Cord wrap
- Lifetime warranty on the heating elements

OPTIONS

- 208/240 volt
- Left hand hinged door
- Additional universal tray slides
- Humidity pan
- Glass door
- School package:* includes a transport latch, 6" modulus casters & fixing rack for 18" x 26" x 1" sheet pans spaced at 1 1/2". This racking does not hold 12" x 20" steam table pans.

VULCAN

a division of ITW Food Equipment Group LLC

P.O. Box 696 ■ Louisville, KY 40201 ■ Toll-free: 1-800-814-2028 ■ Local: 502-778-2791 ■ Quote & Order Fax: 1-800-444-0602



VBP7I
HOLDING & TRANSPORT CABINET

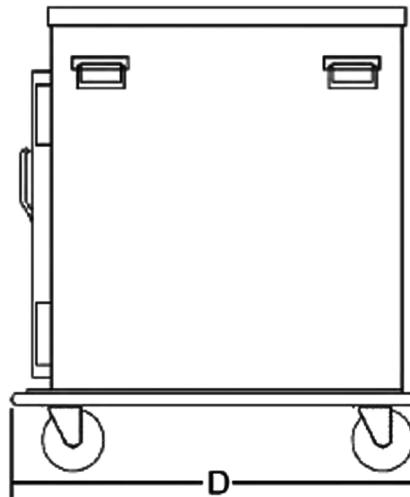
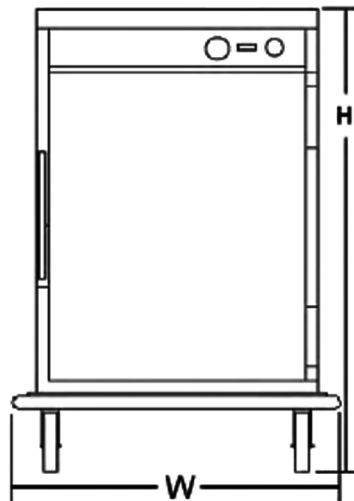
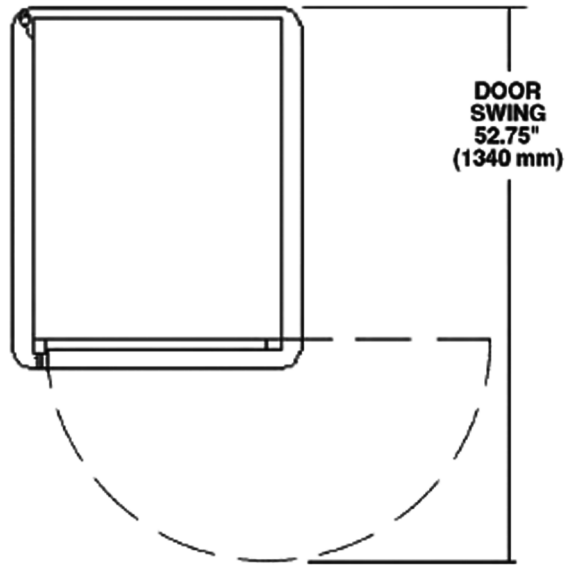

CAPACITY		DIMENSIONS	ELECTRICAL			SHIPPING WEIGHTS
12" x 20" x 2½" PANS	18" x 26" SHEET PANS	EXTERIOR	VOLTS	WATTS	AMPS	LBS / KG
14	7	29" W x 33¾" D x 40" H	120	1,200	10	208 lbs. / 94 kg.



a division of ITW Food Equipment Group LLC

P.O. Box 696 ■ Louisville, KY 40201 ■ Toll-free: 1-800-814-2028 ■ Local: 502-778-2791 ■ Quote & Order Fax: 1-800-444-0602

NOTE: In line with its policy to continually improve its products, Vulcan reserves the right to change materials and specifications without notice.